

**P.E.S. College of Engineering, Mandya - 571 401***(An Autonomous Institution affiliated to VTU, Belgaum)***Fifth Semester, B.E. - Mechanical Engineering****Semester End Examination; Dec – 2016/Jan - 2017****Dynamics of Machines***Time: 3 hrs**Max. Marks: 100*

- Note: i) Answer FIVE full questions, selecting ONE full question from each unit.
ii) Assume suitably missing data, if required.*

UNIT - I

- 1 a. State the conditions for a member to be in equilibrium under, 6
 i) Three forces act. ii) Two forces and torque acts.
- b. In a four bar mechanism shown in Fig. 1 b. Torque T_3 and T_4 have magnitudes 30 N-m and 20 N-m respectively. $AD = 800$ mm, $AB = 300$ mm, $BC = 700$ mm and $CD = 400$ mm. For the equilibrium of the mechanism, find the input torque T_2 . 14
2. For the static equilibrium of the mechanism shown in Fig. 2. Find the required input torque on link 2. The dimensions are $AD = 200$ mm, $AB = 60$ mm, $BC = 200$ mm, $DE = 160$ mm, $CE = 40$ mm and $EF = 180$ mm. 20

UNIT - II

3. A horizontal gas engine running at 210 rpm has a bore of 220 mm and a stroke of 440 mm. The connecting rod is 924 mm long and the reciprocating parts weighs 20 kg. When the crank has turned through an angle of 30° from the inner dead centre, the gas pressure on the cover and crank sides are 500 kN/m^2 and 60 kN/m^2 respectively. Diameter of the piston rod is 40 mm. Determine; 20
 i) Turning moment on the crank shaft
 ii) Thrust on the bearings
 iii) Acceleration of the fly wheel which has a mass of 8 kg and radius of gyration of 600 mm while the power of the engine is 22 kW.
4. The crank and connecting rod of a vertical petrol engine running at 1800 rpm are 60 mm and 270 mm respectively. The diameter of the piston is 100 mm and mass of the reciprocating parts is 1.2 kg during the expansion stroke when the crank has turned 20° from the top dead centre the gas pressure is 650 kN/m^2 . Determine the; 20
 i) Net force on the piston
 ii) Net load on the gudgeon pin
 iii) Thrust on the cylinder walls
 iv) Speed at which the gudgeon pin load is reserved in direction.

UNIT - III

- 5 a. Write the turning moment diagram for a four stroke cycle internal combustion engine with suitable explanation. 8
- b. The turning moment diagram for one revolution of multi cylinder engine shows the following areas in mm^2 above and below the load torque line, -5, +63, -42, +51, -49, +36, -58, +42 and -38. The vertical and horizontal scales are 1 mm equal to 1000 N-m and 5° respectively. The mean speed is 500 rpm and overall fluctuation of speed is not to exceed 1.5% of the mean speed, Determine; 12
- i) Mass of flywheel
- ii) Cross sectional area of rim, if the mean peripheral speed is limited to 15 m/s.
- Assume the mass of the rim is 90% of the mass of the flywheel and mass density of the fly wheel material is 7200 kg/m^3 .
6. The cycle of operations performed by a machine extends over three revolutions the required has a constant value of 400 N-m for one revolution, zero for next revolution. 550 N-m for the first half of the third revolution and zero for the second half. If the driving torque is constant. The mean speed is 180 rpm and the fly wheel has a mass of 500 kg and radius of gyration of 0.5 m. Calculate the; 20
- i) Power required
- ii) Percentage of fluctuation of speed
- iii) Greatest acceleration and retardation.

UNIT - IV

- 7 a. Obtain the expression for balancing of several masses in single plane by analytical method. 6
- b. A shaft carries three masses m_1 , m_2 and m_3 of magnitude of 0.5 kg, 0.75 kg and 0.25 kg respectively and revolving at radii 150 mm, 100 mm and 225 mm. The distance between the planes m_1 and m_2 is 275 mm and m_2 and m_3 is 300 mm the angle between the centres of mass m_1 , m_2 and m_3 relative to horizontal axis are 30° , 300° and 135° respectively, measured in anticlockwise direction. Balancing masses are to be placed in planes A and B. The distance between the planes m_1 and A is 75 mm and is placed between planes m_1 and m_2 . The distance between the planes m_3 and B is 125 mm and is at the extreme end, If the balancing masses revolve at a radius of 250 mm, find the magnitude of A and B and their angular positions. 14
- 8 a. Obtain the expression for magnitude and direction of primary force and secondary force for V-type engine. 6
- b. A three cylinder engine has the cranks spaced at equal angular intervals of 120° . Each crank is 0.15 m long and each connecting rod. is 0.625 m long. The pitch of the cylinder is 0.45 m and the speed is 500 rpm. If the reciprocating parts per cylinder have a mass of 70 kg. Find the maximum unbalanced primary and secondary effects of the reciprocating parts. 14
- (Assume the vertical cylinder engine).

UNIT - V

- 9 a. Write the difference between the functions of flywheel and governor. 5
- b. The turbine rotor of a ship has a mass of 2 tons and rotates at 1800 rpm clockwise when viewed from the aft. The radius of gyration of the rotor is 0.35 m. Determine the gyroscopic couple and its effect when, 15
- i) The ship turns right at a radius of 200 m with a speed of 15 knots
 - ii) The ship pitches with the bow raising at an angular velocity of 0.08 rad/s
 - iii) The ship rolls at an angular velocity of 0.1 rad/s [1 knot = 1.853 km/hr].
- 10 a. Explain the different types of governors. 5
- b. Each wheel of a four wheeler, rear engine has a moment of inertia of 2.4 kg-m^2 and an effective diameter of 0.66 m. The rotating parts of the engine have a moment of inertia of 1.2 kg-m^2 . The gear ratio of engine to the back axle is 3 : 1. The engine is parallel to the rear axle and the crank shaft rotates in the same sense as the road wheels. The mass of the vehicle is 2200 kg and centre of the mass is 0.55 m above the road level. The trace width of the vehicle is 1.5 m. Determine the limiting speed of the vehicle around a curve with 80 m radius so that all the four wheels maintain contact with the road surface. 15

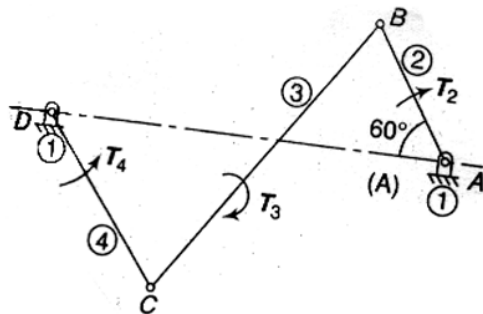

Fig 1-b

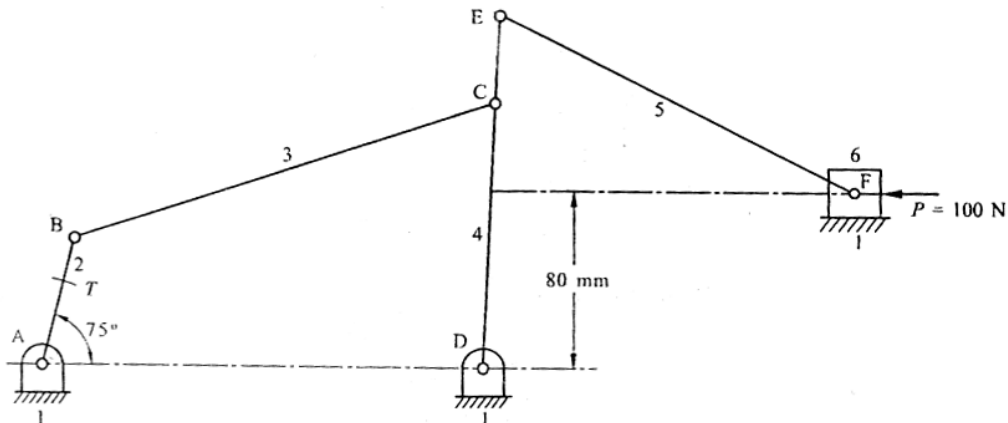

Fig: 2
