



P.E.S. College of Engineering, Mandya - 571 401
 (An Autonomous Institution affiliated to VTU, Belagavi)
Second Semester, B.E. - Semester End Examination; June - 2017
Engineering Mechanics
 (Common to all Branches)

Time: 3 hrs

Max. Marks: 100

Note: i) Answer **FIVE** full questions, selecting **ONE** full question from each unit.
 ii) Missing data, if any, may be suitably assume.

UNIT - I

- 1 a. State and explain basic idealization in mechanics. 6
- b. A collar which may slide on vertical rod is subjected to three forces as shown in Fig. 1b. Determine;
- i) The value of angle ' α ' for which the resultant is horizontal
- ii) The corresponding magnitude of the resultant.

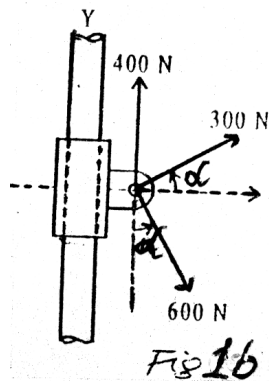

7

- c. For the brake pedal shown in Fig. 1c, determine the smallest force P which has a 104 N-m clockwise moment about B .

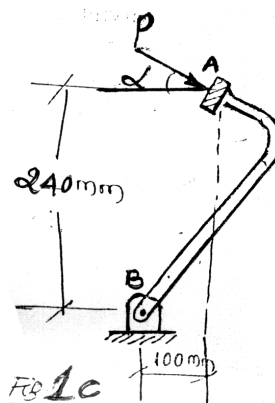

7

- 2 a. What is meant by 'Statistically determinate structure'? Give examples. 2
- b. Illustrate with neat sketches, the reactions developed for different types of support. 6
- c. For the beam illustrated in Fig. 2(c) determine the distance ' x ' so that the reactions R_A and R_B are equal. 6

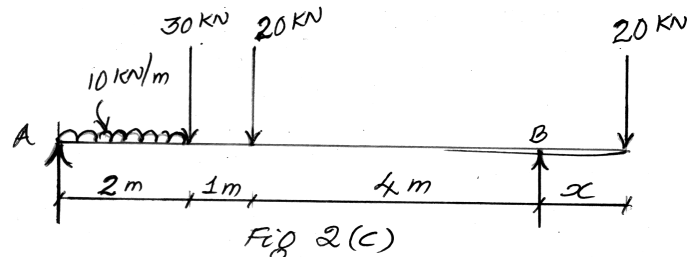

d. Find the reactions for a cantilever beam shown in Fig. 2(d).

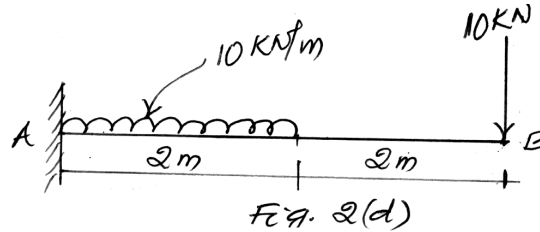

6

UNIT - II

3 a. Locate the centroid of the shaded area with respect to the axes shown in Fig. 3(a).

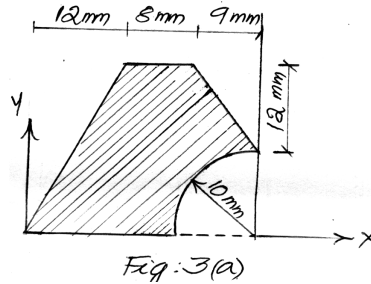

10

b. Locate the centroid of the lamina shown in Fig. 3(b) with respect to point O.

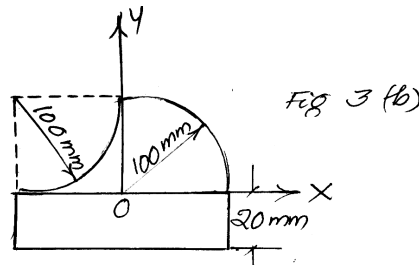

10

4 a. From first principles, show that centroid of a triangle lies at a distance $h/3$ from base where 'h' is the height of the triangle.

5

b. Fig. 4(b) indicates a symmetric triangle being removed from a square of side 100 mm. Determine the height of the triangle removed, so that the vertex of the triangle removed is the new centroid.

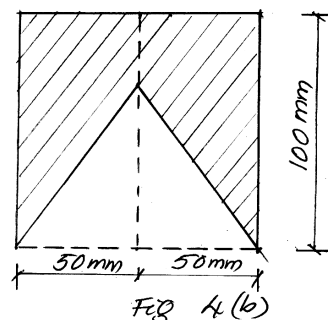

5

- c. Locate the centroid of the shaded area indicated in Fig. 4(c) with respect to OX and OY .
All dimensions in mm.

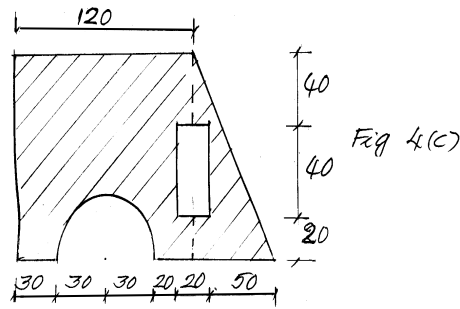

10

UNIT - III

- 5 a. With the aid of neat sketch, write the expression for 'Radius of gyration'.
- b. The second moment of area 'A' about two parallel axes differ by $15 \times 10^6 \text{ mm}^4$. Determine the area of the plane shown in Fig. 5(b).

5

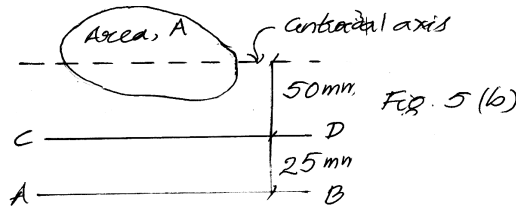

5

- c. Determine the moment of Inertia about centroidal axis parallel to the base of the shaded area shown in Fig. 5(c). Also find the radius of gyration about the same.

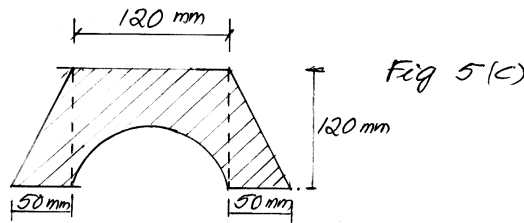

10

- 6 a. With the help of neat sketch, write the statement of parallel axis theorem and perpendicular axis theorem (Derivation not required).
- b. With a neat sketch, explain polar moment of Inertia. Substantiate with equations.
- c. Compute moment of Inertia of shaded area about centroidal axes shown in Fig. 6(c)

6

4

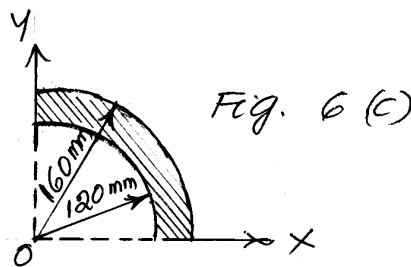

10

UNIT - IV

- 7 a. State the laws of static friction and kinetic friction.
- b. Define coefficient of friction. Show that the coefficient of friction is tangent of the angle of friction.

6

4

- c. A 4 m ladder supported by wall and floor is on the verge of sliding motion. Coefficient of friction is 0.3 between the wall and floor is 0.5. The weight of ladder is 200 N and supports weight of 800 N at a distance of 3 m from bottom and along its length. Compute the reaction at the floor and wall. Also find the angle between the floor and ladder when it is on the verge of motion. 10
- 8 a. What is meant by angle of repose? Show that angle of repose is equal to angle of friction. 6
- b. Explain : 4
- i) Angle of friction ii) Cone of friction.
- c. For the system indicated in Fig. 8c. Find the horizontal force P that should be applied so as to cause impending motion to the left. Assume co-efficient of friction between all contacts surfaces to be 0.35. Also find the tension in the string. 10

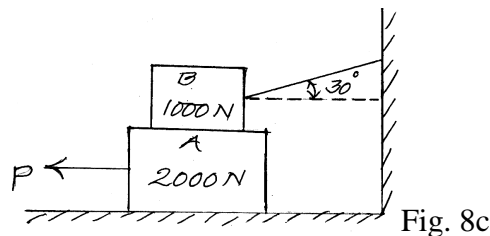

UNIT - V

- 9 a. Define work, power and energy, mention their SI units. 6
- b. Define : 4
- i) Displacement ii) Velocity iii) Speed iv) Acceleration.
- c. A person of 70 kg occupies a lift. Determine the pressure exerted by person on the lift, if it
- i) Moves upwards with an accelerations of 0.8 m/s^2
- ii) Moves downwards with an acceleration of 0.8 m/s^2 5
- iii) Also determine downward acceleration, so that the pressure exerted by person on lift is zero.
- d. Write a note on D'Alembert's principle. 5
- 10 a. What is a projectile? Define the following terms : 10
- Angle of projection, Horizontal range, Vertical height and Time of flight.
- b. A cricket ball thrown from a height of 1.8 m above ground level at an angle of 30° with horizontal with a velocity of 12 m/s and is caught by fielder at a height of 0.6 m above the ground. Determine the distance between the two players. 10

* * * *