



P.E.S. College of Engineering, Mandya - 571 401

(An Autonomous Institution affiliated to VTU, Belgaum)

Fifth Semester, B.E. - Civil Engineering

Semester End Examination; Dec - 2016/Jan - 2017

Analysis of Structures - II

Time: 3 hrs

Max. Marks: 100

Note: i) Answer **FIVE** full questions, selecting **ONE** full question from each unit.
 ii) Missing data may suitably assume.

UNIT - I

- Find the forces in the members of plane truss shown in Fig. Q (1) by Strain energy method. Take $E = 200 \text{ GPa}$.

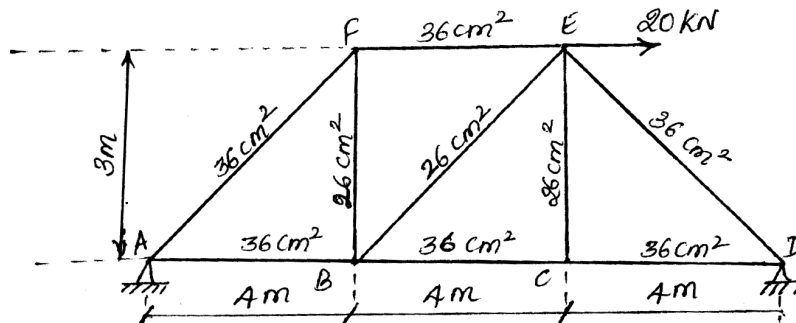

Fig. Q(1)

20

- Determine the forces in all the members of a pin jointed truss shown in Fig. Q (2) using Castiglione's theorem. Assume the cross sectional area of each member to be 10 cm^2 and $E = 200 \text{ GPa}$

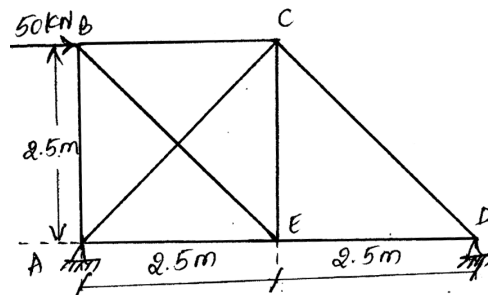

Fig. Q(2).

20

UNIT - II

- Analyse the continuous beam shown in Fig. Q (3) by Slope-deflection method. Draw BMD and SFD.

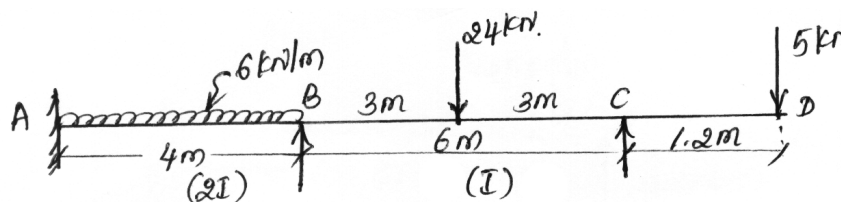

Fig. Q(3)

20

4. Analyse the Frame shown in Fig. Q (4) by Slope-deflection method. Draw BMD and Elastic curve.

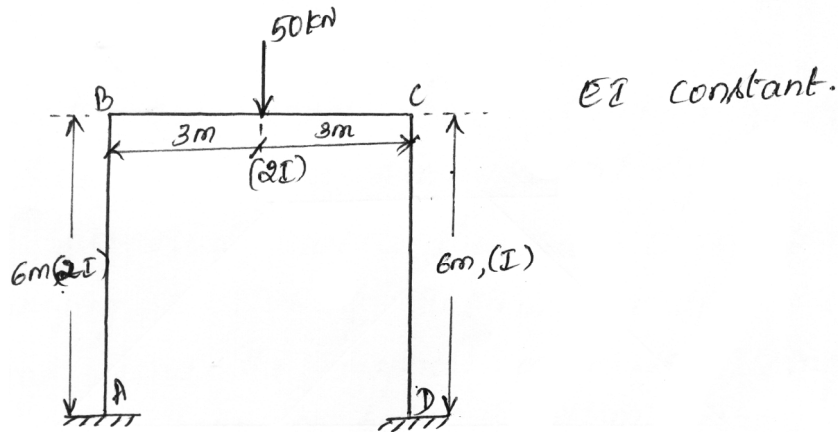

Fig. Q(4).

20

UNIT - III

5. Analyse the continuous beam shown in Fig. Q (5) by Moment-Distribution method. Draw SFD and BMD.

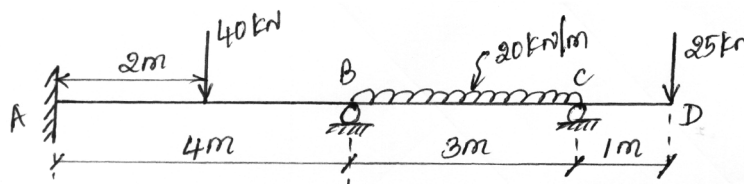

Fig. Q(5).

20

6. Determine the end moments of the members of frame shown in Fig. Q(6) by Moment-Distribution method. Also draw BMD and Elastic curve.

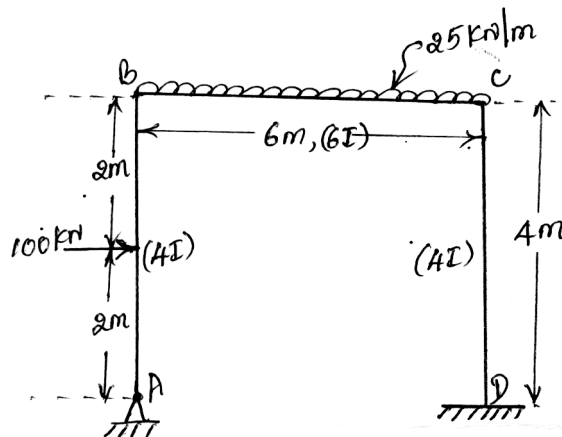
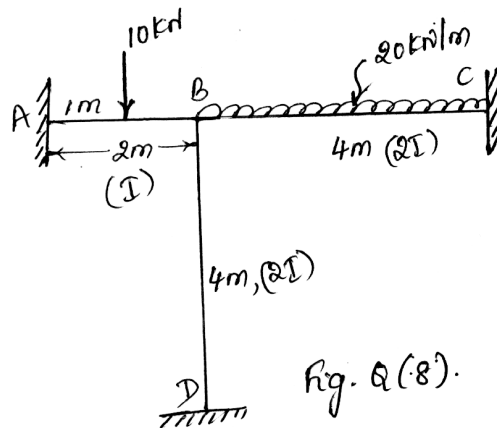

Fig Q(6)

20

UNIT - IV

7. A continuous beam ABC consists of spans AB and BC of lengths 6 m and 4 m respectively. The end A is simply supported while the end C is fixed. The span AB carrying a UDL of 30 kN/m. The span BC does not carry any load. Find the support moments using Kani's method. Also draw SFD, BMD and Elastic curve.
8. Analyse the plane frame shown in Fig. Q(8) by Kani's method. Draw BMD and Elastic curve.



UNIT - V

9. Analyse the continuous beam shown in Fig. Q (9) by Flexibility matrix method, system approach. Draw BMD.

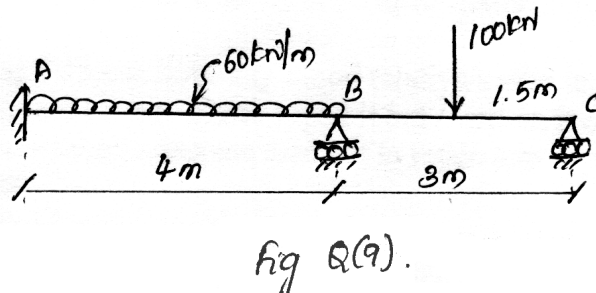

10. Analyse the pin jointed truss shown in Fig. Q(10), by Stiffness matrix method. AE constant.

