



## P.E.S. College of Engineering, Mandya - 571 401

(An Autonomous Institution affiliated to VTU, Belagavi)

**Sixth Semester, B.E. - Automobile Engineering**

**Semester End Examination; July / Aug. - 2022**

**Design of Machine Elements - II**

Time: 3 hrs

Max. Marks: 100

**Note:** Answer **FIVE** full questions, selecting **ONE** full question from each unit.

### UNIT - I

- 1 a. Derive an expression for extreme fiber stresses in curved beam subjected to pure bending. 8
- b. The horizontal c/s of a crane hook is an isosceles triangle of 120 mm deep, the inner width being 90 mm. the hook carries a load of 50kN. Inner radius of curvature is 100 mm. the line of curvature. Determine the stress at the extreme fibers. 12
- 2 a. Define springs and briefly explain the spring terms with neat sketch. 6
- b. Design a helical compression spring for a maximum load of 1000 N and for a deflection of 25 mm the maximum shear stress for the spring wire is  $420 \text{ N/mm}^2$ , modulus of rigidity is  $0.84 \times 10^5 \text{ N/mm}^2$  and value of spring index is 6. 14

### UNIT - II

- 3 a. With a neat sketch derive Lewis equation. 6
- b. In a spur gear arrangement a pinion made of cast steel is rotating at 900 rpm and in driving a cast iron gear at 150 rpm. The teeth are to have standard  $20^\circ$  stub involute profiles and the maximum power to be transmitted is 25 kW. Determine the module and face width. Find the dynamic and wear load also. The pinion has 16 teeth with surface hardness of 250 BHN, take static stress for pinion as 103 MPa and for the gear as 55 MPa. Assume  $E_p = 96.6 \text{ N/m}^2$  and  $E_G = 207 \text{ GN/m}^2$  14
4. The following data refers to the design of a helical gear drive; 20
  - i) Power transmitted 34 kW at 2800 rpm of pinion
  - ii) Speed Ratio 4.5, number of teeth on pinion 18
  - iii) Helix angle  $25^\circ$ , pressure angle  $\alpha = 20^\circ$  stub
  - iv) Material for both pinion and gear is medium carbon steel whose allowable stress may be taken as 230 MPa
  - v) Pinion diameter is limited to 125 mm

Determine the axial thrust on the shaft and check the gears for dynamic and wear loads.

### UNIT - III

5. A pair of straight tooth bevel gears at right angles is to transmit 5 kW at 1200 rpm of the pinion. The diameter of the pinion is 80mm and the velocity ratio is 3.5. The tooth form is  $14.5^\circ$ . Both the pinion and gear are cast iron with allowable stress of  $55 \text{ MN/m}^2$ . 20  
Determine the module, face width from the stand point of strength and also check the design from stand point of dynamic load and wear.

Contd... 2

6. Design a worm drive for a speed reducer to transmit 30 kW at a worm speed of 600 rpm. The required velocity ratio 25:1. The worm is made of C30 heat treated steel and the worm wheel is made of phosphor bronze. The service conditions are intermitted operations with medium shock loads. Also calculate the heat dissipation through the drive

20

**UNIT - IV**

- 7 a. A single plate friction clutch of both sides effective has 0.3 m outer diameter and 0.16 m inner diameter. The co-efficient of friction is 0.2 and it runs at 1000 rpm. Find the power transmitted for uniform wear and uniform pressure distribution cases if the allowable maximum pressure is 0.08 MPa.

10

- b. A multiple disc clutch of steel on bronze category is to transmit 4 kW at 750 rpm. The inner diameter of contact is 80 mm and the outer diameter of contact is 140 mm. The clutch operates in oil with a coefficient of friction of 0.1. The average allowable maximum pressure is 0.35 MPa. Assume uniform wear theory and determine;

10

- i) Number of steel and Bronze disc
- ii) Axial force required

- 8 a. Define brakes and write any four differences between Block brake and Band brake.

8

- b. A single block brake with a torque capacity of 250 N-m is shown in Fig. 8b the brake drum rotates at 100 rpm and the coefficient of friction is 0.35. Calculate;

- i) The actuating force and the hinge pin reaction.
- ii) The rate of heat generation during the braking action.
- iii) The dimensions of the block, if the intensity of pressure between the block and brake drum is 1 MPa. The length of the block is twice the width.

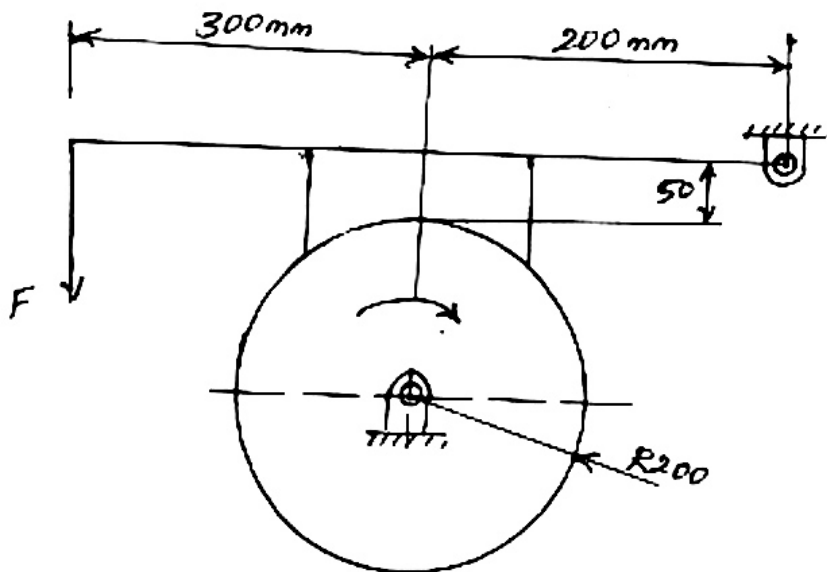

12

Fig:8.b.

## UNIT - V

- 9 a. Derive Petroff's equation. 8
- b. A 75 mm long full radial load of 12 kN at a shaft speed of 1800 rpm. Assume ratio of diameter to the diametrical clearance as 1000. The viscosity of oil is 0.01 Pa-s at the operating temperature. Determine;
- i) Coefficient of friction on Mckee's Equation 12
- ii) Coefficient of friction based on Raimondi and Boys curves
- iii) The probable temperature of the bearing assuming that the heat generated is dissipated in still air at 20°, using Mckee's Equation
- 10 a. List any six types of antifriction bearings and briefly explain any two with neat sketch. 8
- b. Determine the dimensions of a step bearing required to support a load of 20 kN. The shaft speed is 740 rpm. Assume  $d''=0.3d'$ ,  $P = 0.45$  MPa and  $f_c=0.018$ . Also calculate the power lost in friction. 12

\* \* \* \*