



**P.E.S. College of Engineering, Mandya - 571 401**

(An Autonomous Institution affiliated to VTU, Belgaum)

**Fifth Semester, B.E. - Automobile Engineering**

**Semester End Examination; Dec - 2016/Jan - 2017**

**Design of Machine Elements - I**

Time: 3 hrs

Max. Marks: 100

Note: i) Answer **FIVE** full questions, selecting **ONE** full question from each unit.  
 ii) Use of Machine Design Data Hand book is permitted.

**UNIT - I**

- 1 a. Write a note on codes and standardization giving suitable examples. 6
- b. Define and explain with sketch following. 8
  - i) Normal stresses and strain    ii) Shear stress and strain    iii) Bearing stress.
- c. A beam of uniform rectangular cross section is fixed at one end and carries a load of 1000 N at 300 mm from fix end. The maximum bending stress in beam is  $80 \text{ N/mm}^2$ . Find the width and depth of beam, if the depth is twice that of width. 6
- 2 a. A circular rod of diameter 50 mm is subjected to loads as shown in Fig. 1. Determine the nature and magnitude of stress at the critical points. 14

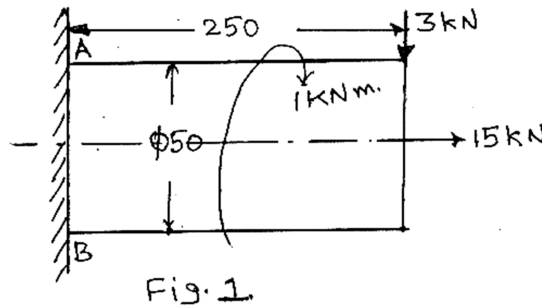

- b. An unknown weight falls through 20 mm on to a collar rigidly attached to the lower end of critical bar 2 m long and  $500 \text{ mm}^2$  in section. If the maximum instantaneous extension is known to be 2 mm, what is the corresponding stress and value of unknown weight? 6  
 Take;  $E = 200 \text{ GPa}$ .

**UNIT - II**

- 3 a. A notched flat plate as shown in Fig. 2 is subjected to bending moment of 10 Nm. Determine the maximum stress induced in the member by taking the stress concentration into accounts. 7

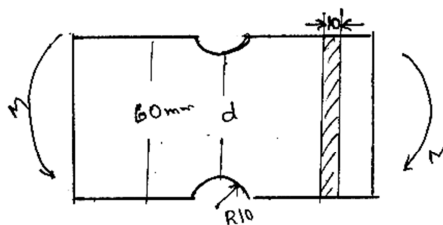

Fig. 2.

- b. Define endurance limit. What are the factors which affect endurance limit? Explain. 8
- c. Write a note on S-N diagram. 5
- 4 a. Derive Soderberg Equation. 5
- b. Hot rolled steel shaft is subjected to a torque that varies from 330 Nm to -110 Nm and a bending moment which varies from 440 Nm to -220 Nm. No key way is present at critical section. Determine the required shaft diameter. Take;  $\sigma_u = 550 \text{ N/mm}^2$ ,  $\sigma_y = 410 \text{ N/mm}^2$ ,  $\sigma_{en} = 275 \text{ N/mm}^2$ , factor of safety = 2, size factor 0.85 and surface factor 0.62. 15

**UNIT - III**

- 5 a. Describe different types of keys with sketch. 8
- b. Design a socket and spigot type cotter joint to sustain an axial load of 100 kN. 12  
Take;  $\sigma_t = 100 \text{ N/mm}^2$ ,  $\sigma_c = 150 \text{ N/mm}^2$  and  $\tau = 60 \text{ N/mm}^2$ .
- 6. A C50Mnl steel shaft transmitting 15 kW at 210 rpm is supported between two bearings 750 mm apart has two gears keyed to it. The pinion having 24 teeth and module 6 mm is located 100 mm to the left of right bearing. This gear delivers horizontally to the right when viewed from left hand bearing. The gear having 80 teeth of module 6 mm is located 150 mm to the right of left bearing and receives from pinions from below. Take  $C_m = 1.75$ ,  $C_t = 1.25$  and  $\phi = 18^\circ$ , consider key effect design the shaft. 20

**UNIT - IV**

- 7 a. Discuss in detail failure of riveted joint. 8
- b. Design a double riveted butt joint with two cover plates for the longitudinal seam of a boiler shell 1.5 m in diameter subjected to a steam pressure of  $0.95 \text{ N/mm}^2$ . Assume an efficiency of 75%,  $\sigma_t = 90 \text{ N/mm}^2$ ,  $\sigma_c = 140 \text{ N/mm}^2$  and  $\tau = 56 \text{ N/mm}^2$ . 12
- 8 a. Explain classification of welded joint. 8
- b. A 16 mm thick plate is welded to a vertical support by two fillet welds as shown in Fig. 3. Determine the size of weld if the permissible shear stress for the weld material is  $75 \text{ N/mm}^2$ . 12

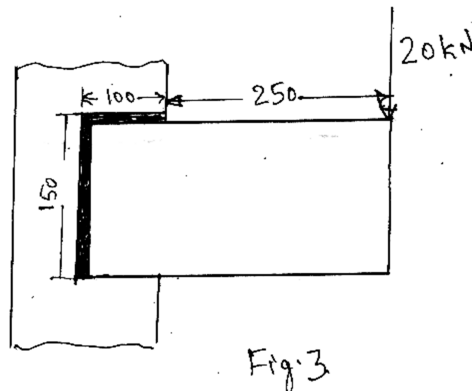

## UNIT - V

- 9 a. With neat diagram explain the threaded screw terminology.
- b. A flat circular plate is used to close the flanged end of a pressure vessel of internal diameter 300 mm. The vessel carries a fluid at a pressure of  $0.7 \text{ N/mm}^2$ . A copper asbestos gasket is used to make the joint leak proof. 12 bolts are used to fasten the cover Plate. Find the size of bolt if stress in bolt is not to exceed  $100 \text{ N/mm}^2$ .
- 10a. Explain self locking and over hauling in power screws. 5
- b. Show that efficiency of self locking screw is less than 50%. 5
- c. An electric motor drives power screw moves a nut in a horizontal plane against a force of 75 kN at a speed of 300 mm/min. The screw has a single thread of 6 mm pitch on a major diameter of 40 mm. the coefficient of friction at thread is 0.1 estimates the power of motor. 10

\* \* \*