

--	--	--	--	--	--	--	--	--	--



## P.E.S. College of Engineering, Mandya - 571 401

(An Autonomous Institution affiliated to VTU, Belgaum)

Third Semester, B.E. - Civil Engineering

Semester End Examination; Dec - 2016/Jan - 2017

Fluid Mechanics

Time: 3 hrs

Max. Marks: 100

**Note:** Answer **FIVE** full questions, selecting **ONE** full question from each unit.

### UNIT - I

- 1 a. Distinguish between :
- i) Real fluid and Ideal fluid 6
  - ii) Weight density and Relative density 6
  - iii) Dynamic viscosity and Kinematic viscosity. 8
- b. If 5 m<sup>3</sup> of certain oil weighs 39240 N. Calculate the weight density, specific mass and relative density of oil. Assume specific weight of water at 4°C as 9810 N/m<sup>3</sup>. 6
- c. A shaft of  $\phi$  20 mm and mass 15 kg slides vertically in a sleeve with a velocity of 5 m/s. The gap between the shaft and the sleeve is 0.1 mm and is filled with oil. Calculate the viscosity of oil, if the length of the shaft is 500 mm. 8
- 2 a. Define;
- i) Specific volume and Specific mass 4
  - ii) Surface tension and Capillarity. 4
- b. Derive the equation for the pressure inside a droplet of water which is excess of outside pressure. 4
- c. Through a very narrow gap of height ( $h$ ), a thin plate of large extent is pulled at a velocity ( $v$ ). On one side of the plate, there is oil of viscosity ( $\mu_1$ ) and on the other side, an oil of viscosity ( $\mu_2$ ). Calculate the position of the plate, so that the, 9
- i) Shear force on the sides of the plate is equal
  - ii) The pull required to drag the plate is minimum.
- d. Make a note on vapour pressure. 3

### UNIT - II

- 3 a. Define Pressure and Pressure head. 4
- b. With neat sketch, explain an inverted differential manometer. 5
- c. Distinguish between gauge pressure and absolute pressure. 4
- d. A vertical pipe line carrying an oil of SG 0.9 is attached with a gauge at A and a manometer as shown in Fig. Q 3(d). What is the gauge reading at 'A'? Also find the absolute reading at A. 7

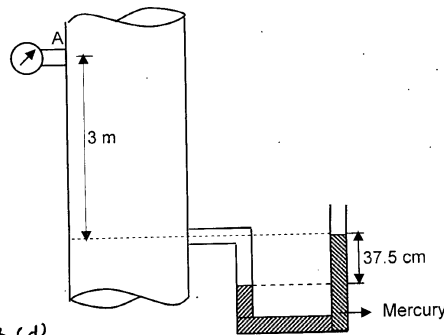

Fig. Q 3 (d)

- 4 a. Define Total pressure and Center of pressure. 4
- b. Explain how the total force on curved surfaces immersed in a static mass of fluid can be found? 6
- c. Calculate the resultant water pressure on the tainter gate of radius 8 m and width unity as shown in Fig. Q 4(c). 10

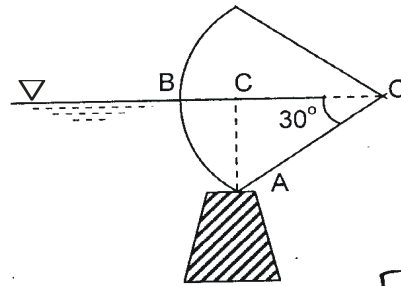

Fig. Q 4(c)

**UNIT - III**

- 5 a. Distinguish between :
  - i) Steady flow and unsteady flow 4
  - ii) Laminar flow and Turbulent flow. 4
- b. Define path line and streak line. 4
- c. Show that the stream lines and equipotential lines meet orthogonally. 4
- d. A stream function in a two dimensional flow is  $\Psi = 2xy$ . Show that the flow is irrotational and determine the corresponding velocity potential. 8
- 6 a. State and Prove Bernoulli's theorem. 7
- b. What is a Pitot tube? Explain the same with a neat sketch. 5
- c. A horizontal Venturimeter with inlet diameter 200 mm diameter and throat diameter 100 mm is used to measure the flow of oil of specific gravity 0.8. The discharge of oil through Venturimeter is 60 lps. Find the reading of the oil-mercury differential manometer. Take  $C_d = 0.98$ . 8

## UNIT - IV

- 7 a. List out the losses that occur in a pipe flow. Give the equation for quantifying them. 8
- b. Explain the phenomenon of water hammer in pipes. 4
- c. Two reservoirs are connected by a 3 km long 250 mm diameter pipe. The difference in water levels of two reservoirs being 10 m. Calculate the discharge in *lpm*, if friction factor = 0.03. Also find the percentage increase in discharge, if a second pipe of same diameter is laid parallel to the first for the last 600 m. 8
- 8 a. Make a note on Pipes in series and Pipes in parallel. 6
- b. Find the diameter of a Galvanized iron pipe required to carry a flow of 40 *lps* of water, if the loss of head is not to exceed 5 m per 1 km length of pipe. Assume friction factor = 0.02. 4
- c. The rate of flow of water through a horizontal pipe is 350 *lps*. The diameter of the pipe is suddenly enlarged from 200 mm to 500 mm. The pressure intensity in the smaller pipe is  $0.15 \text{ N/mm}^2$ . Determine; 10
- (i) Loss of head due to sudden enlargement
- (ii) Pressure intensity in the large pipe
- (iii) Power lost due to enlargement.

## UNIT - V

- 9 a. What is an orifice? Under what circumstance it function as large orifice? 4
- b. Distinguish between suppressed weir and contracted weir. Why the ventilation of suppressed weirs is necessary? 10
- c. Water is to be discharged by two circular orifices under a constant head of 1.0 m, measured from the centre of the orifices. What diameter will be required to give a discharge of  $20 \times 10^3 \text{ m}^3$  per day? Assume  $C_d$  for each orifice as 0.615. 6
- 10 a. Make a note on mouthpieces. 5
- b. Derive the equation for discharge through a triangular notch. 7
- c. A rectangular channel 6 m wide carries a flow of  $1.5 \text{ m}^3/\text{s}$ . A rectangular sharp crested weir is to be installed near the end of the channel to create a depth of 1 m upstream of the weir. Calculate the necessary height. Assume  $C_d = 0.62$ . 8

\* \* \*