



P.E.S. College of Engineering, Mandya - 571 401

(An Autonomous Institution affiliated to VTU, Belgaum)

Seventh Semester, B.E. - Civil Engineering

Semester End Examination; Dec - 2016/Jan - 2017

Design of Steel Structures

Time: 3 hrs

Max. Marks: 100

Note: i) Answer **FIVE** full questions, selecting **ONE** full question from each unit.
 ii) Use of IS 800-2007 and Steel table is permitted

UNIT - I

- 1 a. Explain briefly various types of loads and load combinations to be considered for the design of steel structures. 5
- b. Mention the different types of bolts used to connect the steel structural elements. Explain briefly advantages of HSFG bolts. 5
- c. Find the efficiency of the lap joint shown in Fig.Q1 (c). Given M20 bolts of grade 4.6 and the plates of grade Fe410 (E 250) are provided. (Assume threads in shear plane).

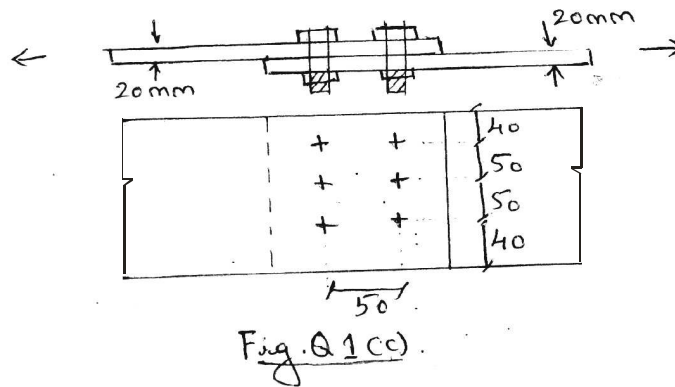

- 2 a. Explain the various modes of failure (behavior) of bolted connections, with neat sketches. 8
- b. A bracket bolted to a vertical column is loaded as shown in Fig. Q2(b). If M20 bolts of grade 4.6 are used, determine the maximum value of factored load 'P', which can be carried safely.

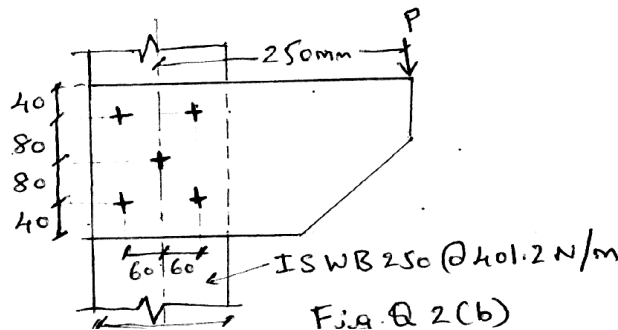

UNIT - II

- 3 a. Explain the defects in welded connections with appropriate figures. 8

- b. A tie member consists of two ISMC 250 at 298.2 N/m. The channels are connected on either side of a 10 mm thick gusset plate (Fe 410 grade). Design the welded joint to develop the full length of the tie. However the overlap is to be limited to 300 mm. Assume connections are made in the workshop. 12
- 4 a. Mention the different types of welds used in practice with sketches. 8
- b. A bracket plate of thickness 10 mm is welded to the flange of a column ISHB 300 at 576.8 N/m to support a load of 250 kN as shown in Fig. Q.4(b). Determine the size of the weld that should be required to support the load.

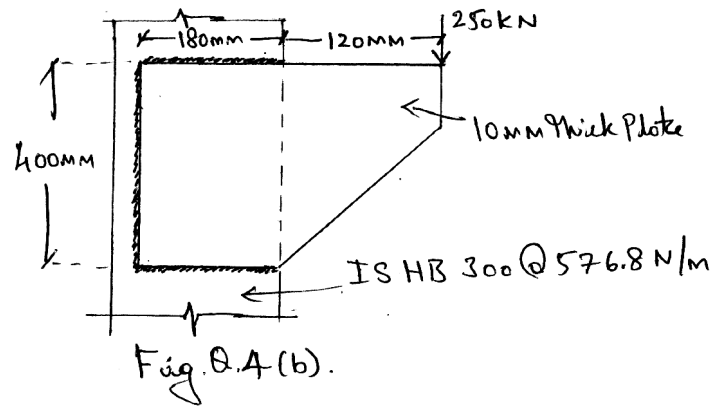

12

UNIT - III

- 5 a. Classify tension members commonly used based on types of structures with sketches. 6
- b. Design tie member consists of a single angle to carry a service tensile force of 150 kN. Use $f_y = 250$ MPa, $f_u = 410$ MPa, 20 mm diameter bolts and also check slenderness ratio ($l = 3.5$ m). 14
- 6 a. What is a lug angles? Explain design principle of lug angle. 6
- b. Determine the design tensile strength of a roof truss diagonal 100 x 75 x 10 mm connected to the gusset plate as shown in Fig. 6(b). Using 5 mm fillet weld and effective length of weld is 200 mm. Use $f_y = 250$ MPa, $f_u = 410$ MPa.

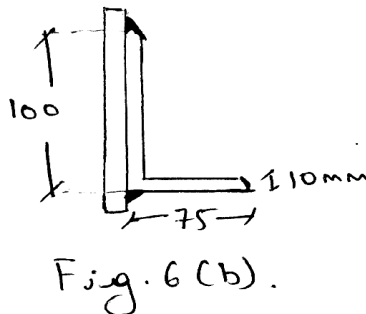

14

UNIT - IV

- 7 a. Write the design steps of load column design as per IS 800-2007. 8

- b. A column consisting of ISHB 400 at 759.2 N/m has a length of 4.5 m. It is hinged at both ends. Determine the axial load carried by column, if $f_y = 250$ MPa, $E = 2 \times 10^5$ MPa. 12
- 8 a. What are column bases? Mention its types and explain design steps of slab base as per IS 800-2007. 8
- b. Design a gusseted base plate on a concrete pedestal for a column ISHB 400 at 759.2 N/m. With two flanges plate 400 x 20 mm carrying a factored load of 4000 kN. The column is to be supported on concrete pedestal to be build with M20 concrete. 12

UNIT - V

- 9 a. Explain the terms : 6
 - i) Plastic moment
 - ii) Shape factor
 - iii) Plastic hinge.
- b. Analyze the continuous beam shown in Fig. Q.9(c). Calculate maximum plastic moment.

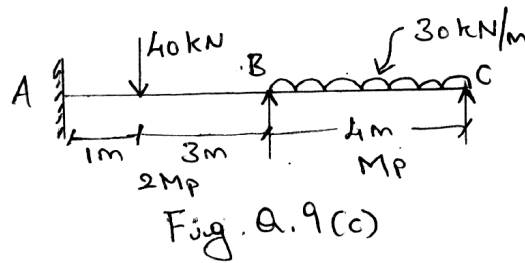

- 10 a. Explain briefly with sketches: 4
 - i) Web buckling
 - ii) Web crippling.
- b. Explain briefly design steps followed while designing laterally supported beam as per IS 800-2007. 6
- c. Determine : 10
 - i) Design bending strength (Take $Z_{pz} = 1176.18$ cm³)
 - ii) Design shear strength
 - iii) Intensity of UDL the beam can carry under service conditions
 - iv) Maximum deflection of simply supported beam as shown in Fig. 10(c).

Assume $f_y = 250$ MPa.

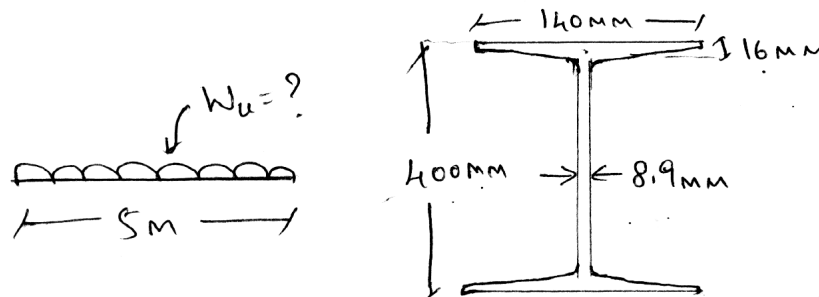

Fig. 10(c).